

# Reverse Osmosis Systems

## Osmostar ED



The Osmostar ED has been specially designed for applications such as certain humidification processes, which require demineralised water at the point of use at pressure. The unique treated water delivery system eliminates both contact with air and contamination from airborne bacteria and particulates.

The incorporation of water quality indication and automatic membrane rinsing, normally reserved for high end applications, ensures stable and continuous high performance with reduced maintenance and without user intervention.

## PRODUCT SPECIFICATION

Model	Osmostar	ED60	ED110	ED190	ED270	ED370	ED540	ED680
Permeate Capacity @ 15°C - 7 bar	l/hr	60	110	190	320	370	540	680
Permeate Capacity @ 15°C - 4 bar	l/hr	100	190	310	550	620	920	1200
Permeate Capacity @ 10°C - 7 bar	l/hr	50	92	160	269	311	454	571
Permeate Capacity @ 10°C - 4 bar	l/hr	84	160	260	462	521	773	1008
Inlet Raw Water (Max)	l/hr	133	253	413	733	827	1227	1600
Pump Type (RV = Rotary Vane)	RV	P0801	P0801	CR3-21	CR3-19	CR3-21	CR3-21	CR3-23
Membranes: (XLE Type)		1 x 2540	2 x 2540	1 x 4040	2 x 4040	2 x 4040	3 x 4040	4 x 4040
Connections Raw Water	DN	20	20	25	20	25	25	25
Permeate	DN	20	20	20	20	20	20	25
Drain (Reject)	DN	32	32	32	32	32	32	32
Power Supply	V/Hz	230/50	230/50	3 x 400/50	3 x 400/50	3 x 400/50	3 x 400/50	3 x 400/50
Installed Power	kW	0.55	0.55	2.2	2.2	2.2	2.2	2.2

## OTHER TECHNICAL DATA

<b>Recovery:</b>	75%
<b>Min/Max Inlet Pressure:</b>	2/5 bar
<b>Min/Max Water Temperature:</b>	5/30°C
<b>Water Quality at Inlet:</b>	1000mg/l TDS softened chlorine free
<b>Working Pressure:</b>	14 bar
<b>Dimensions:</b> Height	1680mm
Width	600mm
Depth	600mm

## DESIGN SUMMARY

Stainless steel box-section frame with plastic mounting panel for instruments and controls.

Polypropylene inlet filter with isolation valves, pressure gauges and 5µ filter cartridge.

Multi-stage or rotary vane high pressure pump.

High performance RO membranes in stainless steel housings.

Valves and instruments including feed water sample valve, pressure switch, permeate and concentrate flow meter, pressure gauges, recycle valve.

PVC stainless steel hoses and inter-connecting pipework.

3030 Control System, using pre-programmed microprocessor for automatic monitoring and control with LCD display of permeate conductivity and plant status, including malfunction indication and alarm output relays.

Permeate delivery unit comprising of stainless steel pressurisation tanks, valves and pressure switch for stop/start control.

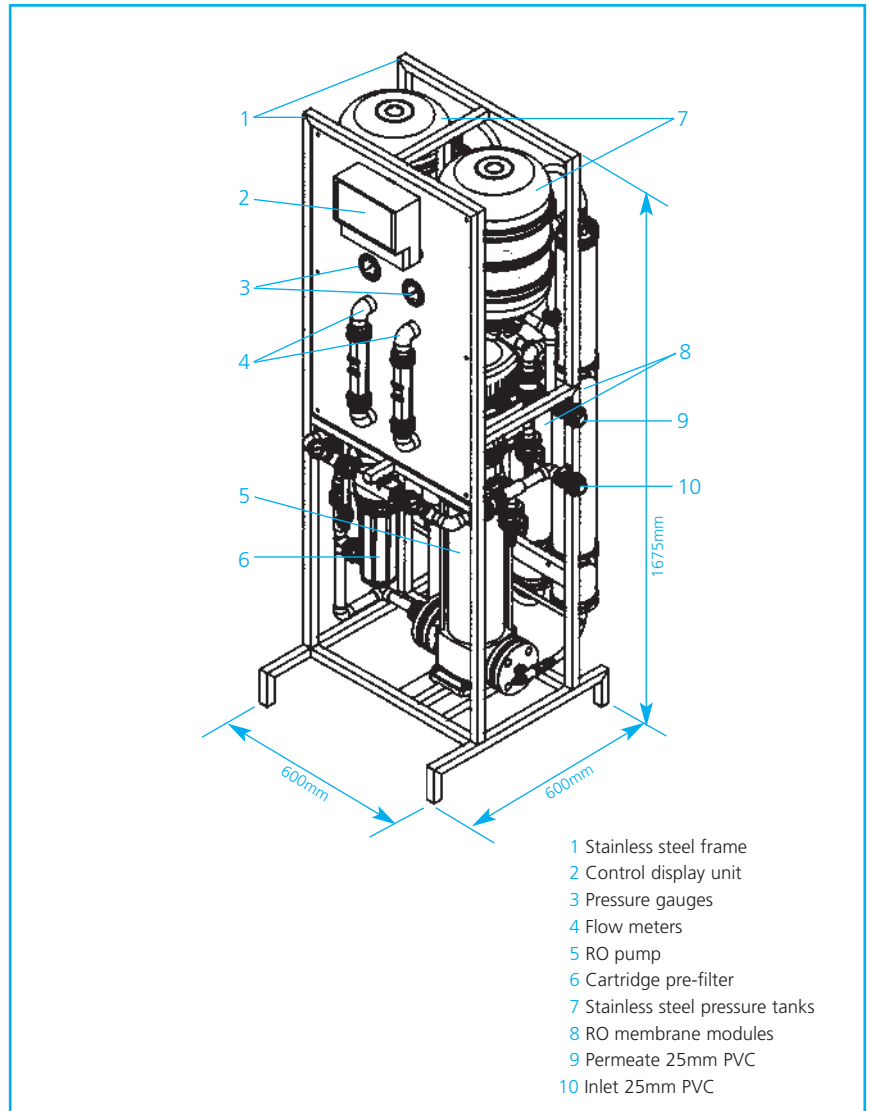

### Lubron UK

Lubron UK Ltd  
14 Commerce Way, Colchester  
Essex CO2 8HH, United Kingdom  
Tel: +44 (0)1206 866444  
Fax: +44 (0)1206 866800  
www.lubron.co.uk

### Lubron Nederland

Lubron Waterbehandeling B.V.  
Mechelaarstraat 38  
4903 RE Oosterhout (NB)  
Postbus 540, Nederland  
Tel: +31 (0)162-426931  
Fax: +31 (0)162-459192  
www.lubronwaterbehandeling.nl

### Lubron België

Lubron Belgium B.V.B.A.  
Antwerpsesteenweg 124  
B-2630 Aartselaar, België  
Tel: +32 (0)3877 1519  
Fax: +32 (0)3877 2884

### Lubron Deutschland

Lubron Wasseraufbereitung GmbH  
Riedstrasse 27  
71691 Freiberg am Neckar  
Deutschland  
Tel: +49 (0)7141 2986130  
Fax: +49 (0)7141 2986159  
www.lubron.de