

Reverse Osmosis Systems

Osmostar



A high quality frame mounted reverse osmosis unit designed for maximum value and performance.

- stainless steel box-section frame and stainless steel membrane housings
- microprocessor control of all functions
- plant status and LCD display of treated water quality
- fully automatic in use
- membrane rinsing for extended membrane life and low maintenance
- on-board particulate filtration of feed water
- low water pressure alarm

PRODUCT RANGE DATA

Model	Osmostar	75	150	250	400	300	600	900	1200	1500
Permeate Capacity @15°C*	l/hr	75	150	250	400	300	600	900	1200	1500
Permeate Capacity @ 10°C*	l/hr	63	126	210	336	252	504	756	1008	1260
Permeate Production/Day	m ³ /day	1.8	3.6	6	9.6	7.2	14.4	21.6	28.8	36
Inlet Raw Water	l/hr	100	200	334	534	400	800	1200	1600	2000
Connections: Raw Water	DN	20	20	20	20	25	25	25	25	25
Permeate	DN	20	20	20	20	20	20	20	25	25
Drain (Reject)	DN	32	32	32	32	32	32	32	32	32
Power Supply	V/Hz	230/50	230/50	230/50	230/50	3 x 400/50	3 x 400/50	3 x 400/50	3 x 400/50	3 x 400/50
Installed Power	kW	0.3	0.55	0.55	0.55	1.1	1.1	1.1	1.5	1.5
Membranes		1 x 2540	2 x 2540	1 x 4040	2 x 4040	1 x 4040	2 x 4040	3 x 4040	4 x 4040	5 x 4040

OTHER TECHNICAL DETAILS

Recovery:	75%
Min/Max Inlet Pressure:	2/5 bar
Min/Max Water Temperature:	5/30°C
Water Quality at Inlet:	1000mg/l TDS softened chlorine free
Rejection Rate:	94/99%
Working Pressure:	10 bar
Dimensions:	
Height	1680mm
Width	600mm
Depth	600mm

DESIGN SUMMARY

Stainless steel box-section frame with plastic mounting panel for instruments and controls.

Polypropylene inlet filter with isolation bars, pressure gauges and 5µ filter cartridge.

Multi-stage or rotary vane high pressure pump.

High performance RO membranes in stainless steel housings.

Valves and instruments including feed water sample valve, pressure switch, permeate and concentrate flow meter, pressure gauges recycle valve.

PVC stainless steel hoses and inter-connecting pipework.

3030 Control System, using pre-programmed microprocessor for automatic monitoring and control with LCD display of permeate conductivity and plant status, including malfunction indication and alarm output relays.

Plant on/off via remote tank level switches.

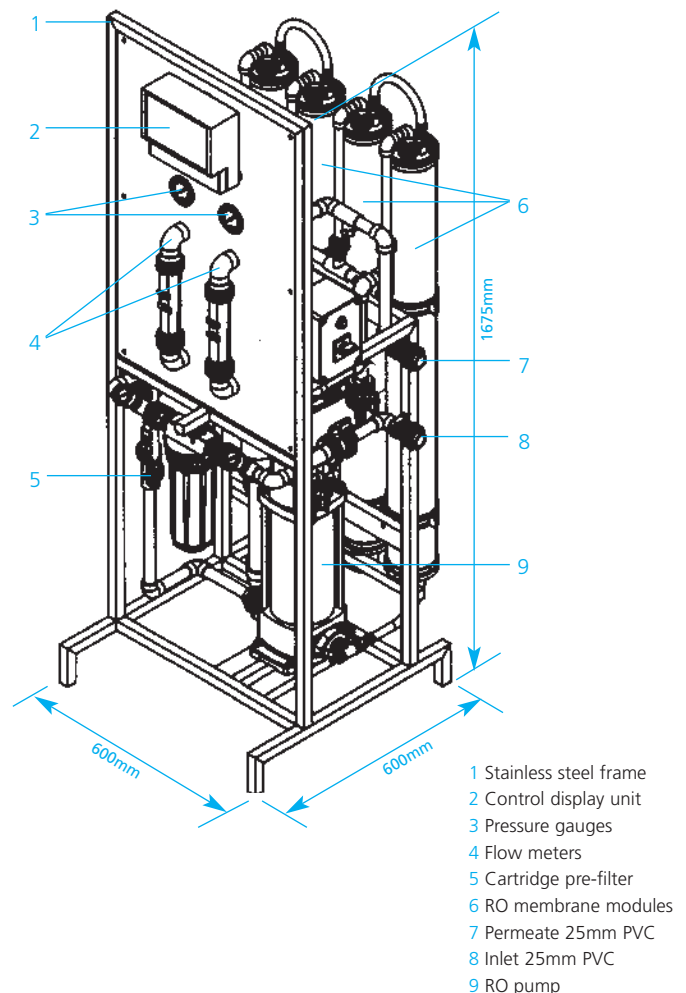

Lubron UK

Lubron UK Ltd
14 Commerce Way, Colchester
Essex CO2 8HH, United Kingdom
Tel: +44 (0)1206 866444
Fax: +44 (0)1206 866800
www.lubron.co.uk

Lubron Nederland

Lubron Waterbehandeling B.V.
Mechelaarstraat 38
4903 RE Oosterhout (NB)
Postbus 540, Nederland
Tel: +31 (0)162-426931
Fax: +31 (0)162-459192
www.lubronwaterbehandeling.nl

Lubron België

Lubron Belgium B.V.B.A.
Antwerpsesteenweg 124
B-2630 Aartselaar, België
Tel: +32 (0)3877 1519
Fax: +32 (0)3877 2884

Lubron Deutschland

Lubron Wasseraufbereitung GmbH
Riedstrasse 27
71691 Freiberg am Neckar
Deutschland
Tel: +49 (0)7141 2986130
Fax: +49 (0)7141 2986159
www.lubron.de